

Dual Channel Synchronized Current Mode PWM

FEATURES

- Single Oscillator Synchronizes Two PWMs
- 150 μ A Startup Supply Current
- 2mA Operating Supply Current
- Operation to 1MHz
- Internal Soft Start
- Full-Cycle Fault Restart
- Internal Leading Edge Blanking of the Current Sense Signal
- 1 Amp Totem Pole Outputs
- 75ns Typical Response from Current Sense to Output
- 1.5% Tolerance Voltage Reference

DESCRIPTION

The UCC3810 is a high-speed BiCMOS integrated circuit which implements two synchronized pulse width modulators for use in off-line and DC-to-DC power supplies.

The UCC3810 provides perfect synchronization between two PWMs by using the same oscillator. The oscillator's sawtooth waveform can be used for slope compensation if required.

Using a toggle flip flop to alternate between modulators, the UCC3810 ensures that one PWM will not slave, interfere, or otherwise affect the other PWM. This toggle flip flop also ensures that each PWM will be limited to 50% maximum duty cycle, insuring adequate off-time to reset magnetic elements.

This IC contains many of the same elements of the UC3842 current mode controller family, combined with the enhancements of the UCC3802. This minimizes power supply parts count. Enhancements include leading edge blanking of the current sense signals, full cycle fault restart, CMOS output drivers, and outputs which remain low even when the supply voltage is removed.

BLOCK DIAGRAM

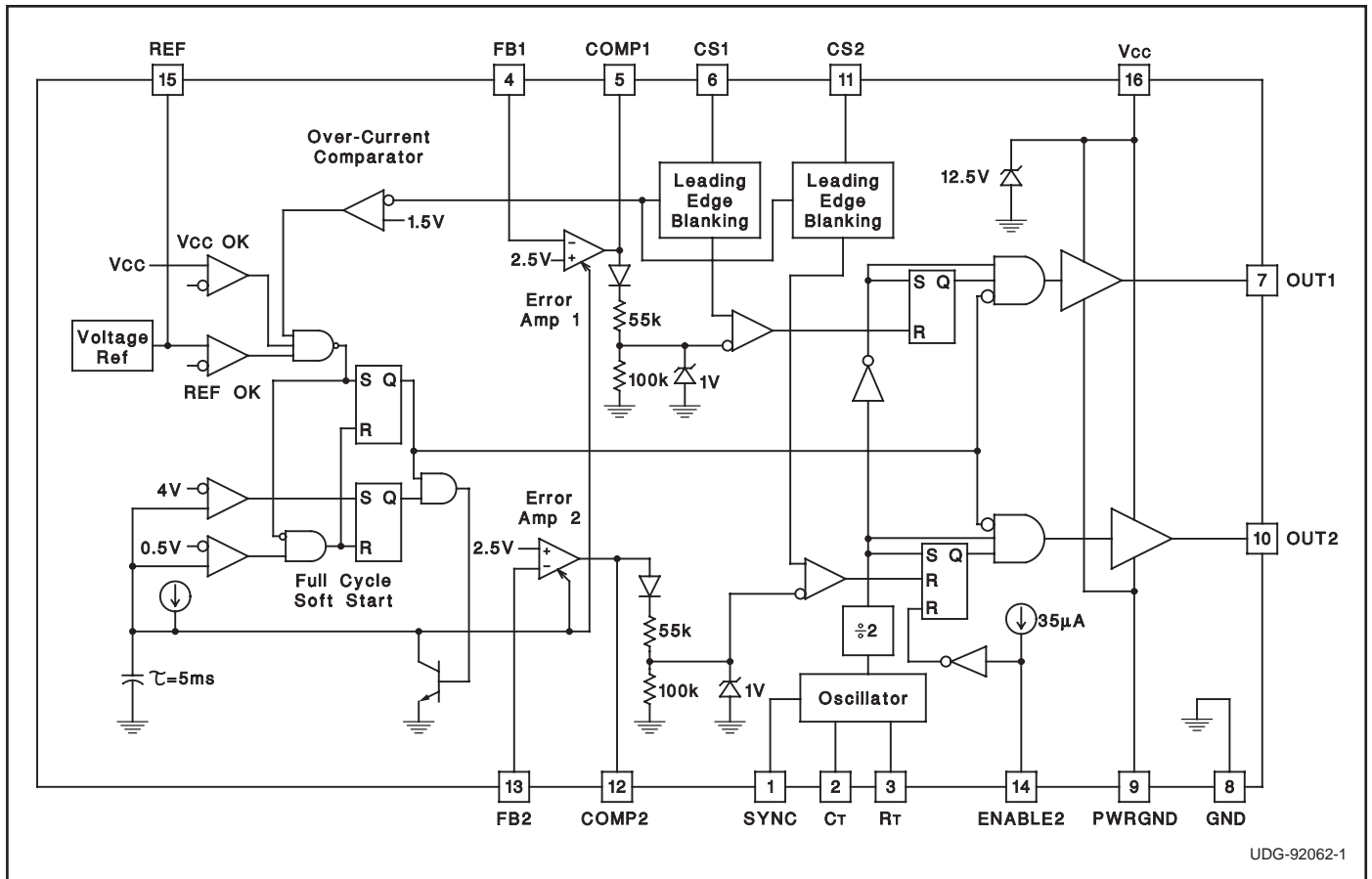

UDG-92062-1

ABSOLUTE MAXIMUM RATINGS

V _{CC} Voltage (Note 3)	11V
V _{CC} Current	20mA
OUT1, OUT2 Current, Peak, 5% Duty Cycle	±1A
OUT1, OUT2 Energy (Capacitive Load)	20μJ
Analog Inputs (FB1, FB2, CS1, CS2, SYNC)	−0.3V to 6.3V
Operating Junction Temperature	+150°C
Storage Temperature Range	−65°C to +150°C
Lead Temperature (Soldering, 10 seconds)	300°C

Note 1: All voltages are with respect to GND. All currents are positive into the specified terminals.

Note 2: Consult Unitorde Integrated Circuits Product & Applications Handbook for information regarding thermal specifications and limitations of packages.

Note 3: In normal operation, V_{CC} is powered through a current limiting resistor. Absolute maximum of 11V applies when driven from a low impedance such that the V_{CC} current does not exceed 20mA.

CONNECTION DIAGRAM

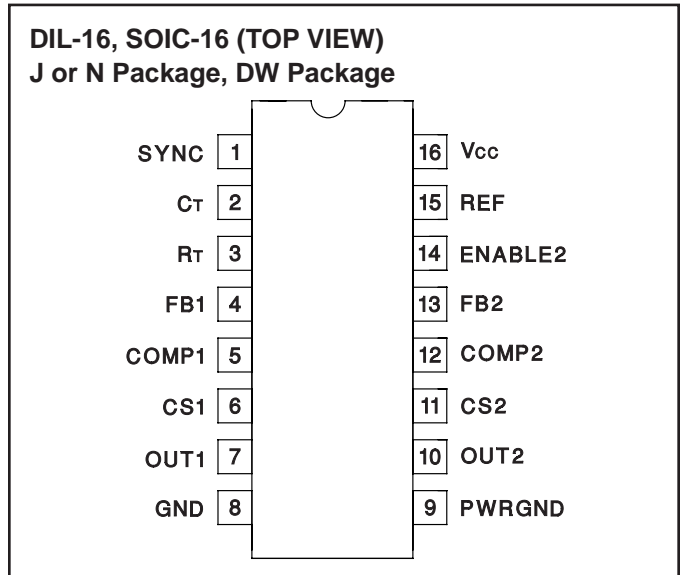

ELECTRICAL CHARACTERISTICS: Unless otherwise stated, these specifications apply for $-55^{\circ}\text{C} \leq T_A \leq 125^{\circ}\text{C}$ for UCC1810; $-40^{\circ}\text{C} \leq T_A \leq 85^{\circ}\text{C}$ for UCC2810; $0^{\circ}\text{C} \leq T_A \leq 70^{\circ}\text{C}$ for UCC3810; V_{CC} = 10V (Note 4); R_T = 150k; C_T = 120pF; No Load; T_A = T_J. All parameters are the same for both channels.

PARAMETER	TEST CONDITIONS	MIN	TYP	MAX	UNITS
Reference Section					
Output Voltage	T _J = 25°C	4.925	5.000	5.075	V
Load Regulation	0mA < I _{REF} < 5mA		5	25	mV
Line Regulation	UVLO Stop Threshold Voltage +0.5V < V _{CC} < Shunt Voltage		12		mV
Output Voltage	Full temperature range, 0mA < I _{REF} < 5mA	4.85	5.00	5.10	V
Output Noise Voltage	10Hz < f < 10kHz, T _J = +25°C (Note 10)		235		μV
Long Term Stability	T _A = +125°C, 1000 Hours (Note 10)		5		mV
Output Short Circuit Current			−8	−25	mA
Oscillator Section					
Oscillator Frequency	R _T = 30k, C _T = 120pF (Note 5)	840	940	1040	kHz
Oscillator Frequency	R _T = 150k, C _T = 120pF (Note 5)	200	220	240	kHz
Temperature Stability	(Note 10)		2.5		%
Peak Voltage			2.5		V
Valley Voltage			0.05		V
Peak-to-Peak Amplitude		2.25	2.45	2.65	V
SYNC Threshold		0.80	1.65	2.2	V
SYNC Input Current	SYNC = 5V		30		μA
Error Amplifier Section					
FB Input Voltage	COMP = 2.5V	2.44	2.50	2.56	V
FB Input Bias Current				±1	μA
Open Loop Voltage Gain		60	73		dB
Unity Gain Bandwidth	(Note 10)		2		MHz
COMP Sink Current	FB = 2.7V, COMP = 1V	0.3	1.4	3.5	mA
COMP Source Current	FB = 1.8V, COMP = 4V	−0.2	−0.5	−0.8	mA
Minimum Duty Cycle	COMP = 0V			0	%
COMP Soft Start Rise Time	FB = 1.8V, Rise from 0.5V to REF−1.5V		5		ms

ELECTRICAL CHARACTERISTICS: Unless otherwise stated, these specifications apply for $-55^{\circ}\text{C} \leq T_A \leq 125^{\circ}\text{C}$ for UCC1810; $-40^{\circ}\text{C} \leq T_A \leq 85^{\circ}\text{C}$ for UCC2810; $0^{\circ}\text{C} \leq T_A \leq 70^{\circ}\text{C}$ for UCC3810; $V_{CC} = 10\text{V}$ (Note 4); $R_T = 150\text{k}$; $C_T = 120\text{pF}$; No Load; $T_A = T_J$. All parameters are the same for both channels.

PARAMETER	TEST CONDITIONS	MIN	TYP	MAX	UNITS
Current Sense Section					
Gain	(Note 6)	1.20	1.55	1.80	V/V
Maximum Input Signal	COMP = 5V (Note 7)	0.9	1.0	1.1	V
CS Input Bias Current				± 200	nA
CS to OUT Propagation Delay	CS steps from 0V to 1.2V, COMP = 2.5V		75		ns
CS Blank Time	(Note 8)		55		ns
CS Overcurrent Threshold		1.35	1.55	1.85	V
COMP to CS Offset	CS = 0V	0.65	0.95	1.4	V
PWM Section					
Maximum Duty Cycle	$R_T = 150\text{k}$, $C_T = 120\text{pF}$ (Note 10)	45	49	50	%
Maximum Duty Cycle	$R_T = 30\text{k}$, $C_T = 120\text{pF}$ (Note 10)	40	45	48	%
Minimum On Time	CS = 1.2V, COMP = 5V		130		ns
Output Section					
OUT Low Level	$I_{OUT} = 20\text{mA}$		0.12	0.42	V
	$I_{OUT} = 200\text{mA}$		0.48	1.10	V
	$I_{OUT} = 20\text{mA}$, $V_{CC} = 0\text{V}$		0.7	1.20	V
OUT High Level ($V_{CC} - \text{OUT}$)	$I_{OUT} = -20\text{mA}$		0.15	0.42	V
	$I_{OUT} = -200\text{mA}$		1.20	2.30	V
OUT Rise Time	$C_{OUT} = 1\text{nF}$		20	50	ns
OUT Fall Time	$C_{OUT} = 1\text{nF}$		30	60	ns
Undervoltage Lockout Section					
Start Threshold		9.9	11.3	13.2	V
Stop Threshold		7.5	8.3	9.5	V
Start to Stop Hysteresis		1.7	3.0	4.7	V
ENABLE2 Input Bias Current	ENABLE2 = 0V	-20	-35	-55	μA
ENABLE2 Input Threshold Voltage		0.80	1.53	2.00	V
Overall Section					
Startup Current	$V_{CC} < \text{Start Threshold Voltage}$		0.15	0.25	mA
Operating Supply Current, Outputs Off	$V_{CC} = 10\text{V}$, FB = 2.75V		2.0	3.0	mA
Operating Supply Current, Outputs On	$V_{CC} = 10\text{V}$, FB = 0V, CS = 0V, $R_T = 150\text{k}$		3.2	5.1	mA
Operating Supply Current, Outputs On	$V_{CC} = 10\text{V}$, FB = 0V, CS = 0V, $R_T = 30\text{k}$		8.5	14.5	mA
V_{CC} Internal Zener Voltage	$I_{CC} = 10\text{mA}$ (Note 9)	11.0	12.9	14.0	V
V_{CC} Internal Zener Voltage Minus Start Threshold Voltage		0.4	1.2		V

Note 4: Adjust V_{CC} above the start threshold before setting at 10V.

Note 5: Oscillator frequency is twice the output frequency. $F_{OSC} \approx \frac{4}{RT \times CT}$

Note 6: Current Sense Gain A is defined by: $A = \frac{\Delta V_{COMP}}{\Delta V_{CS}}$ $0 \leq V_{CS} \leq 0.8\text{V}$.

Note 7: Parameter measured at trip point of latch with FB = 0V.

Note 8: CS Blank Time is measured as the difference between the minimum non-zero on-time and the CS to OUT delay.

Note 9: Start Threshold Voltage and V_{CC} Internal Zener Voltage track each other.

Note 10: Guaranteed by design. Not 100% tested in production.

PIN DESCRIPTIONS

COMP1, COMP2: The low impedance outputs of the error amplifiers.

CS1, CS2: The current sense inputs to the PWM comparators. These inputs have leading edge blanking. For most applications, no input filtering is required. Leading edge blanking disconnects the CS inputs from all internal circuits for the first 55ns of each PWM cycle. When used with very slow diodes or in other applications where the current sense signal is unusually noisy, a small current sense RC filter may be required.

CT: The timing capacitor of the oscillator. Recommended values of C_T are between 100pF and 1nF. Connect the timing capacitor directly across C_T and GND.

ENABLE2: A logic input which disables PWM 2 when low. This input has no effect on PWM 1. This input is internally pulled high. In most applications it can be left floating. In unusually noisy applications, the input should be bypassed with a 1nF ceramic capacitor. This input has TTL compatible thresholds.

FB1, FB2: The high impedance inverting inputs of the error amplifiers.

GND: To separate noise from the critical control circuits, this part has two different ground connections: GND and PWRGND. GND and PWRGND must be electrically connected together. However, use care to avoid coupling noise into GND.

OUT1, OUT2: The high current push-pull outputs of the PWM are intended to drive power MOSFET gates through a small resistor. This resistor acts as both a current limiting resistor and as a damping impedance to minimize ringing and overshoot.

PWRGND: To separate noise from the critical control circuits, this part has two different ground connections: GND and PWRGND. GND and PWRGND must be electrically connected together.

REF: The output of the 5V reference. Bypass REF to GND with a ceramic capacitor $\geq 0.01\mu\text{F}$ for best performance.

RT: The oscillator charging current is set by the value of the resistor connected from RT to GND. This pin is regulated to 1V, but the actual charging current is $10\text{V}/R_T$. Recommended values of R_T are between 10k and 470k. For a given frequency, higher timing resistors give higher maximum duty cycle and slightly lower overall power consumption. Supply current decreases with increased R_T by the relationship:

$$\Delta I_{CC} = \frac{11\text{V}}{R_T}$$

For more information, see the detailed oscillator block diagram.

SYNC: This logic input can be used to synchronize the oscillator to a free running oscillator in another part. This pin is edge triggered with TTL thresholds, and requires at least a 10ns wide pulse. If unused, this pin can be grounded, open circuited, or connected to REF.

VCC: The power input to the IC. This pin supplies current to all functions including the high current output stages and the precision reference. Therefore, it is critical that V_{CC} be directly bypassed to PWRGND with an $0.1\mu\text{F}$ ceramic capacitor.

APPLICATION INFORMATION

Leading Edge Blanking and Current Sense

Figure 1. shows how an external power stage is connected to the UCC3810. The gate of an external power N-channel MOSFET is connected to OUT through a small current limiting resistor. For most applications, a 10Ω resistor is adequate to limit peak current and also practical at damping resonances between the gate driver and the MOSFET input reactance. Long gate lead length increases gate capacitance and mandates a higher series gate resistor to damp the RLC tank formed by the lead, the MOSFET input reactance, and the UCC3810 driver output resistance.

The UCC3810 features internal leading edge blanking of the current sense signal on both current sense inputs. The blank time starts when OUT rises and continues for 55ns. During that 55ns period, the signal on CS is ignored. For most PWM applications, this means that the CS input can be connected to the current sense resistor as shown above. However, high speed grounding practices and short lead lengths are still required for good performance.

APPLICATION INFORMATION (cont.)

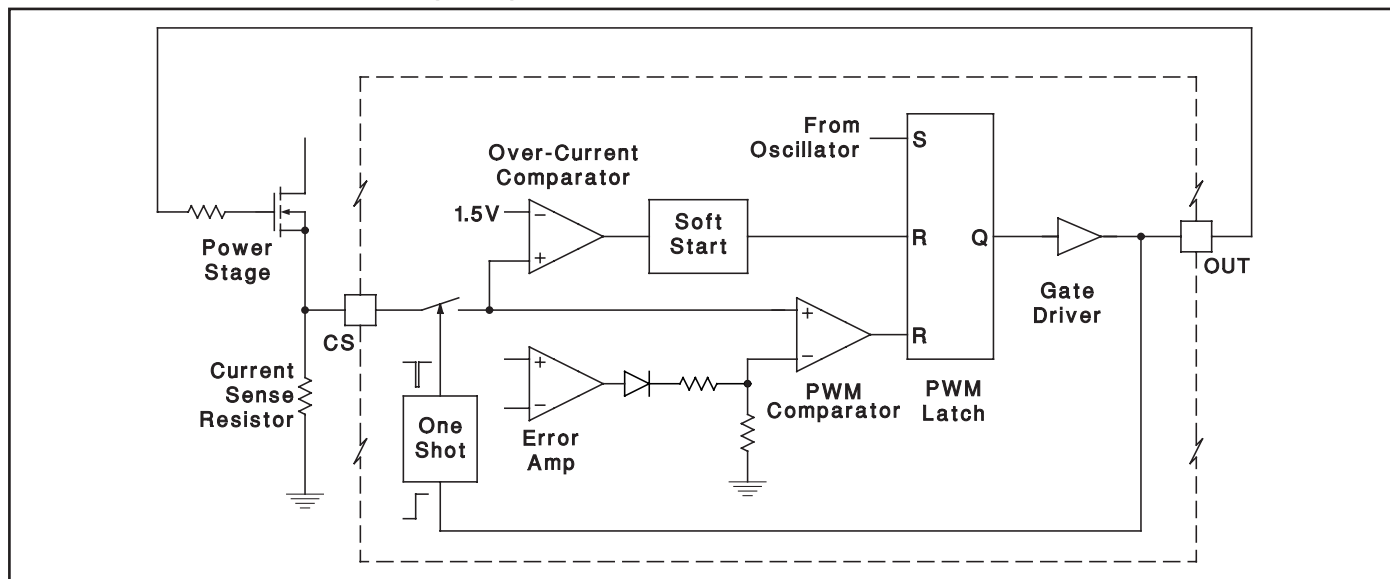

Figure 1. Detailed block diagram.

Oscillator

The UCC3810 oscillator generates a sawtooth wave at CT. The sawtooth rise time is set by the resistor from RT to GND. Since RT is biased at 1V, the current in RT is $1V/RT$. The actual charging current is 10 times higher. The fall time is set by an internal transistor on-resistance of approximately 100Ω . During the fall time, all outputs are off and the maximum duty cycle is reduced below 50%. Larger timing capacitors increase the discharge time and reduce frequency. However, the percentage

maximum duty cycle is only a function of the timing resistor RT and the internal 100Ω discharge resistance.

Error Amp Output Stage

The UCC3810 error amplifiers are operational amplifiers with low output resistance and high input resistance. The output stage of one error amplifier is shown above. This output stage allows the error amplifier output to swing close to GND and as high as one diode drop below 5V with little loss in amplifier performance.

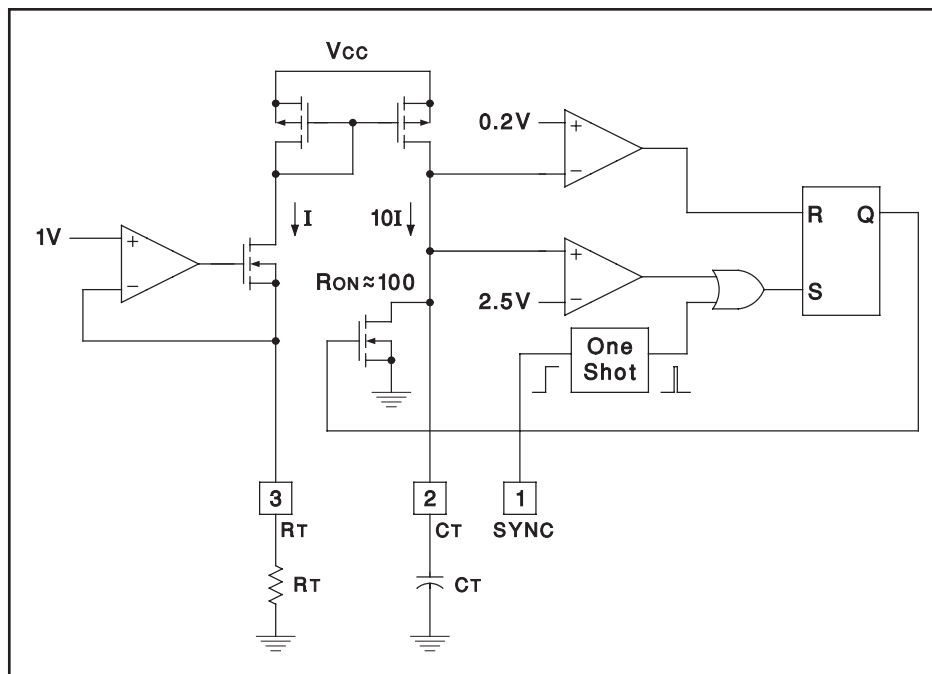

Figure 2. Oscillator.

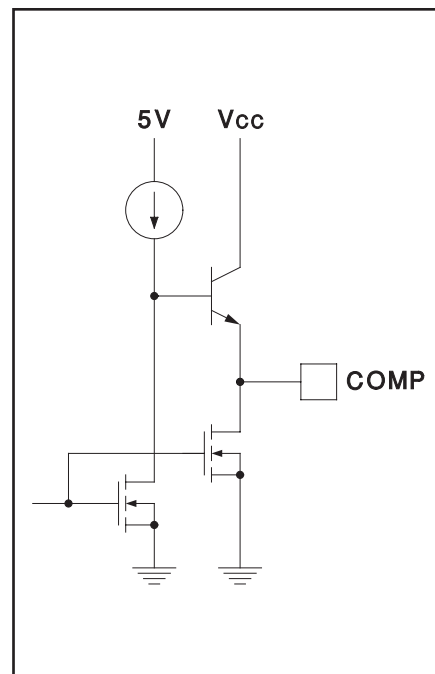

Figure 3. Error amp output stage.

TYPICAL CHARACTERISTICS

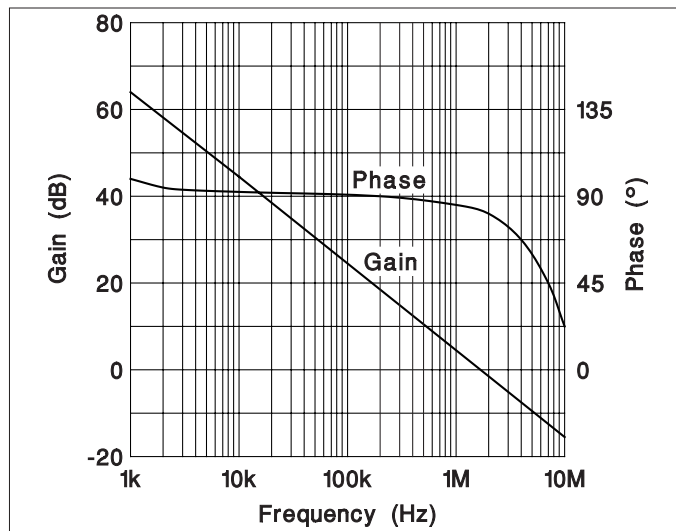

Figure 4. Error amp and gain phase response.

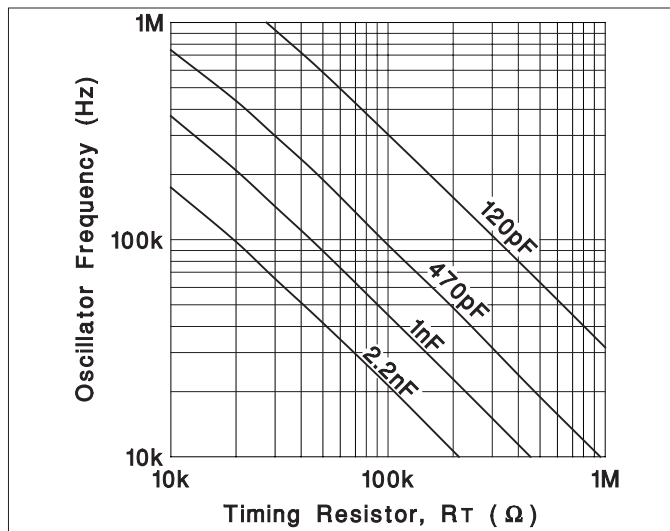

Figure 7. Oscillator frequency vs. R_T and C_T .

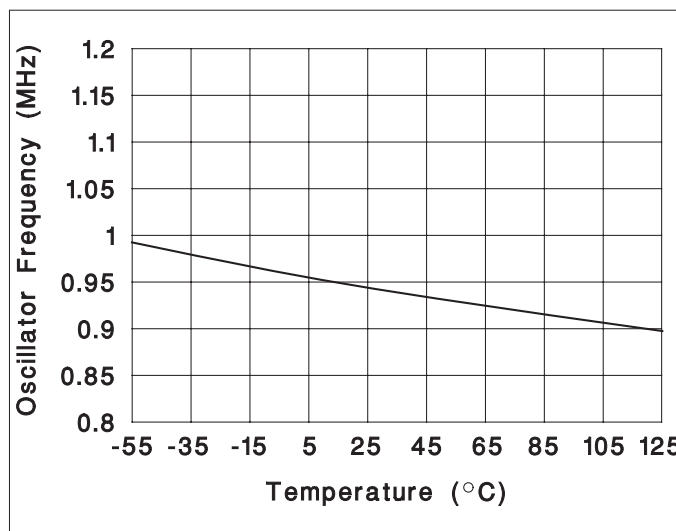

Figure 5. Oscillator frequency vs. temperature.

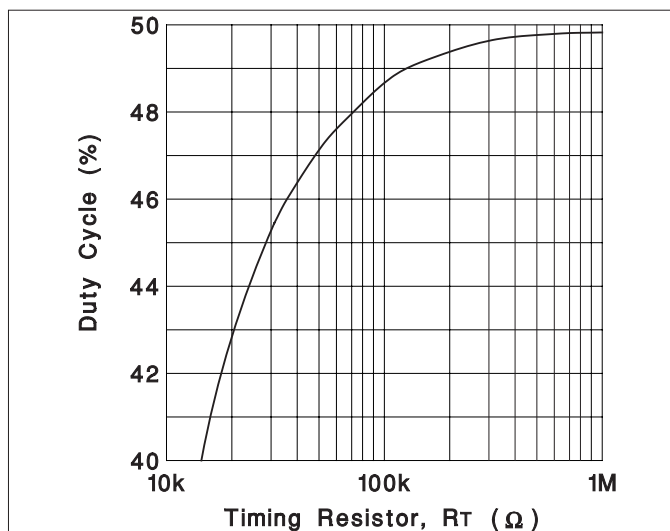

Figure 8. Maximum duty cycle vs R_T .

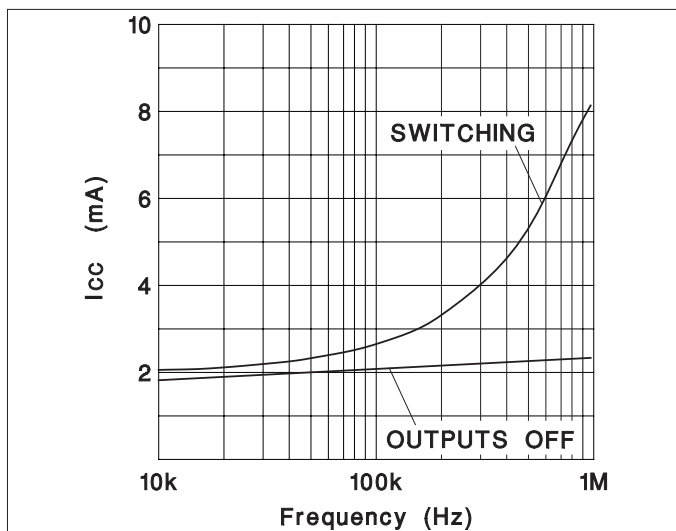

Figure 6. I_{CC} vs. oscillator frequency.

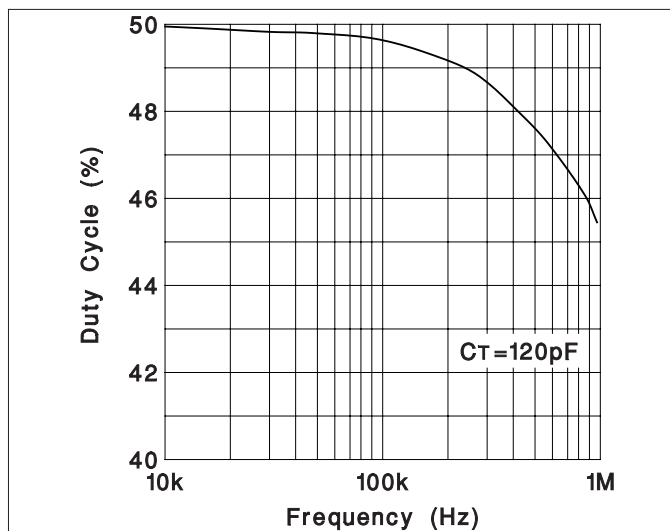

Figure 9. Maximum duty cycle vs. frequency.

APPLICATION INFORMATION (cont.)

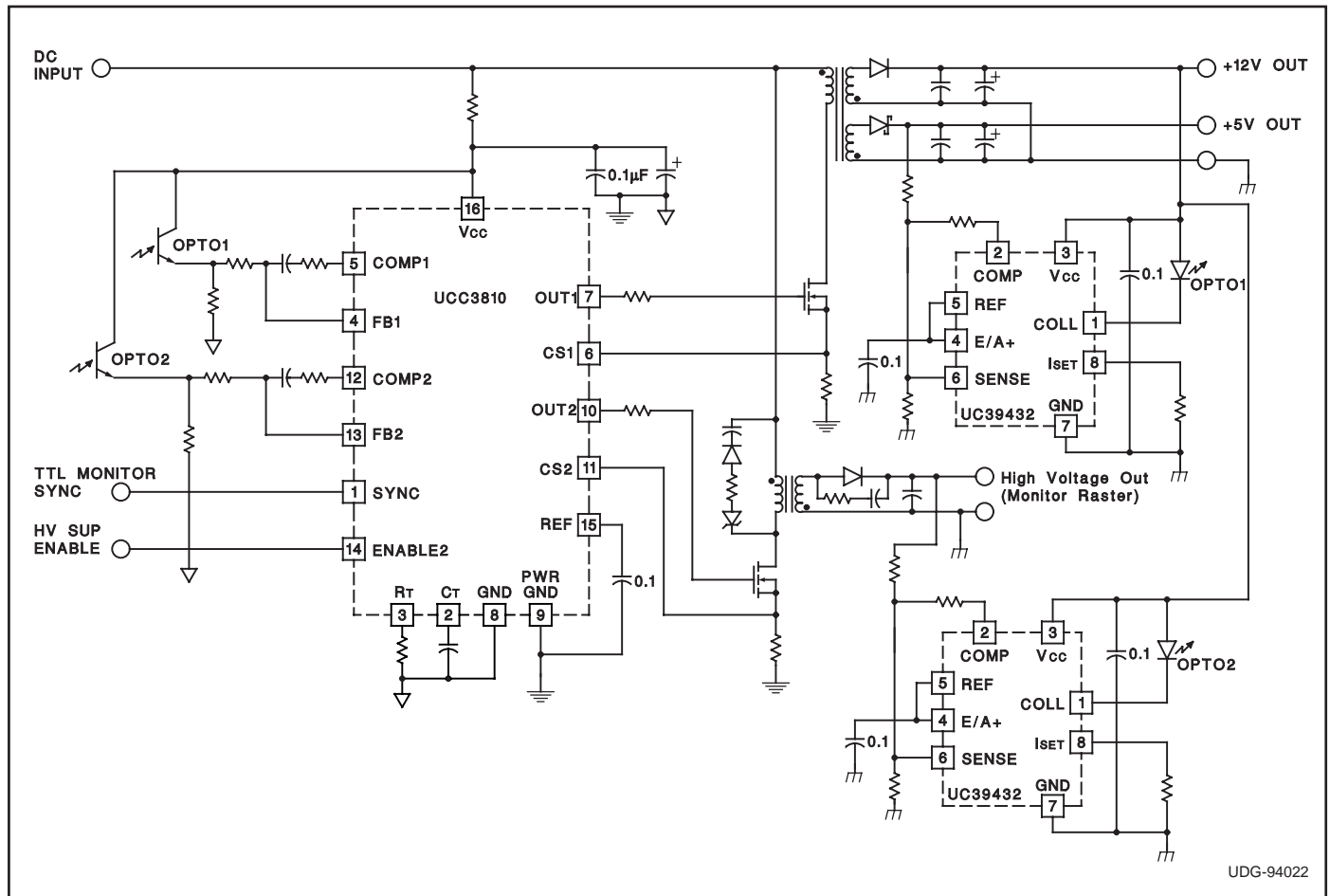

Figure 10. Typical application.

IMPORTANT NOTICE

Texas Instruments and its subsidiaries (TI) reserve the right to make changes to their products or to discontinue any product or service without notice, and advise customers to obtain the latest version of relevant information to verify, before placing orders, that information being relied on is current and complete. All products are sold subject to the terms and conditions of sale supplied at the time of order acknowledgement, including those pertaining to warranty, patent infringement, and limitation of liability.

TI warrants performance of its semiconductor products to the specifications applicable at the time of sale in accordance with TI's standard warranty. Testing and other quality control techniques are utilized to the extent TI deems necessary to support this warranty. Specific testing of all parameters of each device is not necessarily performed, except those mandated by government requirements.

CERTAIN APPLICATIONS USING SEMICONDUCTOR PRODUCTS MAY INVOLVE POTENTIAL RISKS OF DEATH, PERSONAL INJURY, OR SEVERE PROPERTY OR ENVIRONMENTAL DAMAGE ("CRITICAL APPLICATIONS"). TI SEMICONDUCTOR PRODUCTS ARE NOT DESIGNED, AUTHORIZED, OR WARRANTED TO BE SUITABLE FOR USE IN LIFE-SUPPORT DEVICES OR SYSTEMS OR OTHER CRITICAL APPLICATIONS. INCLUSION OF TI PRODUCTS IN SUCH APPLICATIONS IS UNDERSTOOD TO BE FULLY AT THE CUSTOMER'S RISK.

In order to minimize risks associated with the customer's applications, adequate design and operating safeguards must be provided by the customer to minimize inherent or procedural hazards.

TI assumes no liability for applications assistance or customer product design. TI does not warrant or represent that any license, either express or implied, is granted under any patent right, copyright, mask work right, or other intellectual property right of TI covering or relating to any combination, machine, or process in which such semiconductor products or services might be or are used. TI's publication of information regarding any third party's products or services does not constitute TI's approval, warranty or endorsement thereof.